



◆ **RESINDEK<sup>®</sup> FLOORING  
CARE & MAINTENANCE**

CARE & MAINTENANCE MANUAL

# TABLE OF CONTENTS

## CLEANING & MAINTENANCE

---

Cleaning Your ResinDek® Floor .....	<b>3</b>
<i>How do I clean my ResinDek® Floor?</i> .....	3
<i>How do I remove tough stains?</i> .....	3
<i>What about the expansion gaps?</i> .....	3
<i>How can we be sure that the use of Floor Scrubbers is a safe process?</i> .....	3
Repairing Minor Scratches .....	<b>4</b>
Repairing Deep Gouges, Screw or Bolt Holes .....	<b>5</b>
Repairing Areas with Excessive Wear - 2100MV Caulk .....	<b>6</b>

## FLOOR PANEL REPLACEMENT

---

Panel Removal & Replacement .....	<b>7</b>
Fasteners / Fixings Installation .....	<b>9</b>
<i>Depth of Fasteners / Fixings</i> .....	9
Grounding Screw Fasteners / Fixings Installation .....	<b>10</b>
<i>ResinDek® ESD Grounding Screws</i> .....	10



## 1. Cleaning Your ResinDek® Floor

### *How do I clean my ResinDek® Floor?*

No matter the finish of your ResinDek flooring, the surface can be easily cleaned using a damp mop or standard cleaning solvents without fear of damaging the surface. Cleaning solutions that have worked particularly well include water, diluted isopropyl alcohol (3 parts water to 1 part alcohol), and many off the shelf detergents (**no degreasers**). We recommend testing a small area of the floor first with the cleaner of choice.

Avoid prolonged soaking, hosing down, or wetting of all ResinDek® products. However, walk behind scrubbers, such as Tennant micro scrubbers (see right), can provide an efficient method for daily cleaning without jeopardizing the 10 year warranty. These machines can also withdraw the liquids from the panel surfaces in a short period of time to reduce any risk of temporary edge swelling. Please ensure all pads are clean so unwanted debris is not introduced that could possibly scratch or gouge the floor finish.



### *How do I remove tough stains (i.e. grease, permanent marker, paint)?*

Acetone, also known as nail polish remover, will eliminate hard-to-remove stains and will not harm the ResinDek® finishes. **Do not use methylene chloride or paint thinners.**

### *What about the expansion gaps?*

The 1/8" (3mm) gaps will begin to shrink as the panels begin to take on humidity and moisture from the ambient conditions. Once they stop growing, they rarely open back up unless located in an uncontrolled environment in an area with extremely dry conditions. While the edges are not usually coated, standard cleaning procedures and chemicals are still acceptable. The board itself is moisture resistant and will withstand small amounts of water and other liquids.

### *How can we be sure that the use of Floor Scrubbers is a safe process?*

Cornerstone has a home improvement client that has approximately 25 different warehouse dc's in service with large elevated platforms decked with ResinDek® panels. These warehouses have been in service for an average of 3 to 4 years, and are being cleaned once per week with the same Tennant T1 Scrubbers. At a recent site visit, the floors were observed to be in excellent condition.

Using the Tennant T1 or T2 Scrubbers on the ResinDek® panels as outlined above will in no way adversely impact our 10 year warranty on this floor.



## 2. Repairing Minor Scratches

---



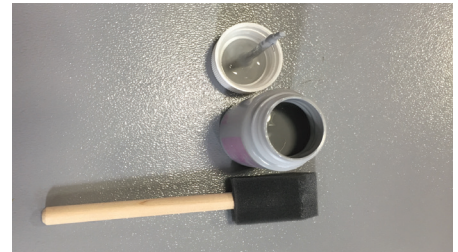
### 1. Contact Us

Contact Cornerstone Specialty Wood Products® for recommended touch-up paint and repair kit.



### 2. Clean Area

Thoroughly clean area to be repaired with a damp cloth. Then dry completely.



### 3. Prep Foam Brush

Depending upon the size use either the 1" (25.4mm) foam brush or the small artist brush enclosed in the kit.



### 4. Apply Touch Up Paint

Thoroughly shake the touch up paint before applying. Allow a minimum of 15 minutes for the first coat of paint to dry. If necessary add a second coat of paint.



### 5. Cure

Allow 24 hours to fully cure before touching the repaired area.



### 3. Repairing Deep Gouges, Screw or Bolt Holes



#### 1. Contact Us

Contact Cornerstone Specialty Wood Products® for recommended touch-up paint and repair kit.



#### 2. Clean Area

Thoroughly clean area to be repaired with a damp cloth. Then dry completely.



#### 3. Cut Off Repair Putty

Using a standard utility knife cut off required amount of ResinDek® epoxy repair putty.



#### 4. Mix Putty

Mix ResinDek® epoxy putty by kneading with fingers until a uniform color is achieved. If mixing is difficult, warm to room temperature or slightly above. For best results dampen fingers prior to mixing.



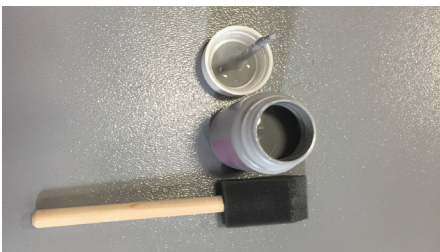
#### 5. Apply Putty

Apply to surface to be repaired within 10 minutes of mixing. For best adhesion force putty into any cracks or holes and strike off excess material with a tool moistened with clean water. Allow putty to cure for 60 minutes.



#### 6. Sand & Clean Area

After area has fully cured, sand area with 80 grit sandpaper, using a palm sander or sanding block. Clean area after sanding with a damp cloth to remove dust.



#### 7. Prep Foam Brush

Depending upon the size use either the 1" foam brush or the small artist brush enclosed in the kit.



#### 8. Apply Touch Up Paint

Thoroughly shake the touch up paint before applying. Allow a minimum of 15 minutes for the first coat of paint to dry. If necessary add a second coat of paint.







## 4. Repairing Areas with Excessive Wear - 2100MV Caulk



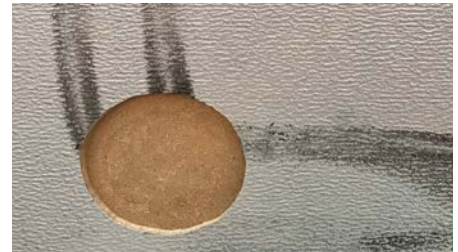
### 1. Identify Damage

Identify the damaged caster snap location.



### 2. Outline Area

Outline the area that needs to be repaired.



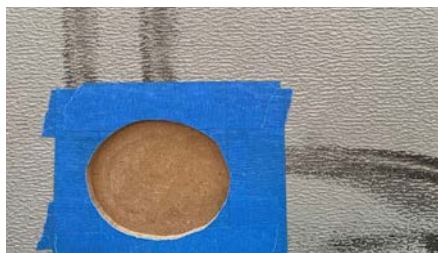
### 3. Route Area

Route out the area of the repair 1/8" to 1/4" deep.



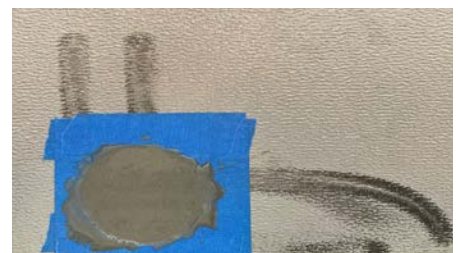
### 4. Apply Painters Tape

Place painters tape over the repair area.



### 5. Remove Tape

Remove the tape covering the repair area only, leaving excess tape around the repair area.



### 6. Mix 2100MV

Mix the 2100MV per the product instructions and fill in repair area. \*Ensure entire routed area is filled to the brim and flush with surface of coating.

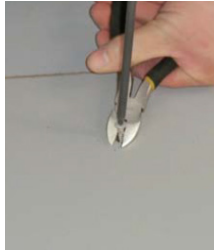


### 7. Remove Tape and Cure

Remove the tape and allow the repair area to cure per the product instructions for at least 24 hours.



## 5. Panel Removal & Replacement



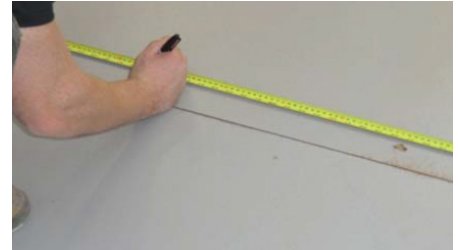
### 1. Remove Screws

Remove grounding screws, then use pliers to assist with removal of regular fasteners / fixings.



### 2. Set Circular Saw

Set circular saw to .0394" (1mm) thinner than ResinDek® Panel depth (18mm is recommended).



### 3. Mark Cut Centers

Mark the cut centers of the ResinDek® panels.



### 4. Draw Chalk Lines

Draw the chalk lines for the cuts that you are going to make.



### 5. Cut Panel

Cut the ResinDek® panel as marked with chalk line - Be careful that the B Deck is not damaged during this process by cutting too deeply.



### 6. Cut Across Internal Corner

Cut across an internal corner to assist with the panel removal.



### 7. Cut all Panel Edges

Cut all of the external ResinDek® panel edges at T&G joints. Hand chisel out remaining .0394" (1mm) of all cuts as needed.



### 8. Panel Removal

Remove the internal corner piece and remove all 4 sections of the panel to be replaced.

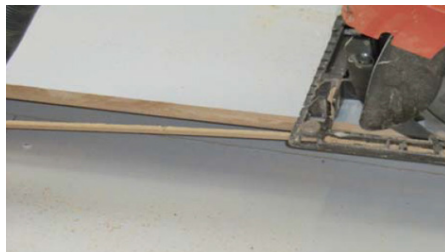


### 9. Fit Valley Shims

Fit valley shims to all 4 sides between old adjacent panels and new to support replacement ResinDek® panel. Do not overlap valley shims.



## 6. Panel Removal & Replacement (cont.)



### 10. Panel Tongue Removal

Remove the ResinDek® panel tongue over the length of the replacement board - replacement panel now has 2 grooves and 2 square edges.



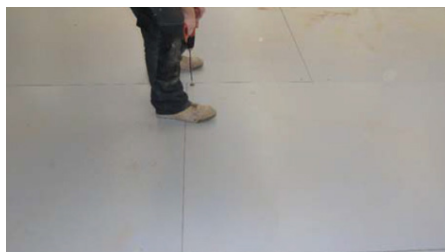
### 11. Fit Panel into Place

Clear all debris where the replacement ResinDek® panel is to be installed. Position replacement panel into open space.



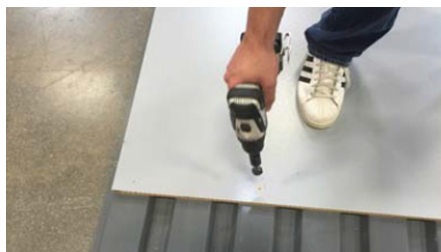
### 12. Tap Panel into Place

Tap replacement panel into place. Ensure ResinDek® panel is central and that all perimeter edges have even gaps 0.197" (5mm).



### 13. Fit Grounding Screws

Install grounding screws at the corners.



### 14. Install Counter Bores

Using a counter bore bit, mark your rib centers. Counter bores show rib centers after they are no longer visible.



### 15. Install Countersunk Screws

Fully fix the ResinDek® panel with countersunk screws.

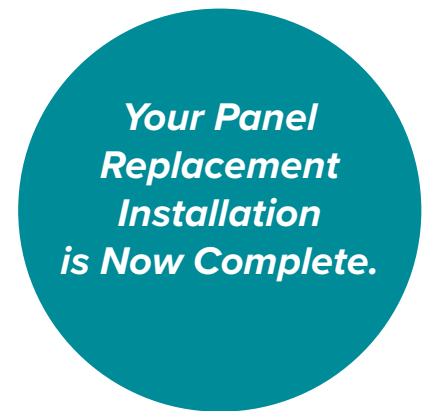
*For water type flooring option, see additional steps below.*

### 16. Insert Foam Backer Rod

Insert 1/4" (6.35mm) dia. foam backer rod to all (4) perimeter gaps around the ResinDek panels, pressing to the bottom of the gap.

### 17. Caulk gaps

Use a manual dual tube caulk gun to fill the gaps with JF-311 Polyurea joint filler per manufacturer instructions.





## 7. Fasteners / Fixings Installation

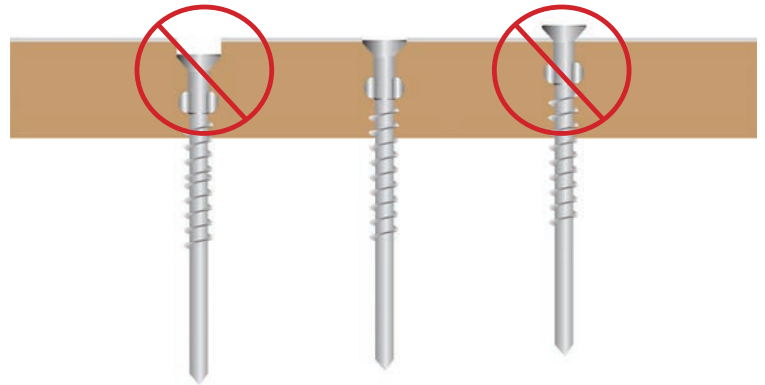
### Depth of Fasteners / Fixings

Care should be taken to install ResinDek® fasteners / fixings in accordance with Cornerstone Installation Instructions. The proper depth is important for cosmetic, but not structural reasons. The diagram below (*Figure E*) illustrates the proper depth of the fixing vs. the fasteners / fixings installed too deep, and not deep enough.

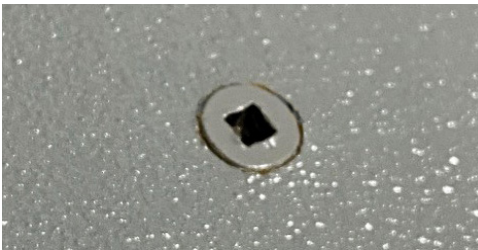


*ResinDek® Top Side Fasteners / Fixings*  
 Part No. COR8030 (Gray)  
 Part No. COR8038 (Beige)

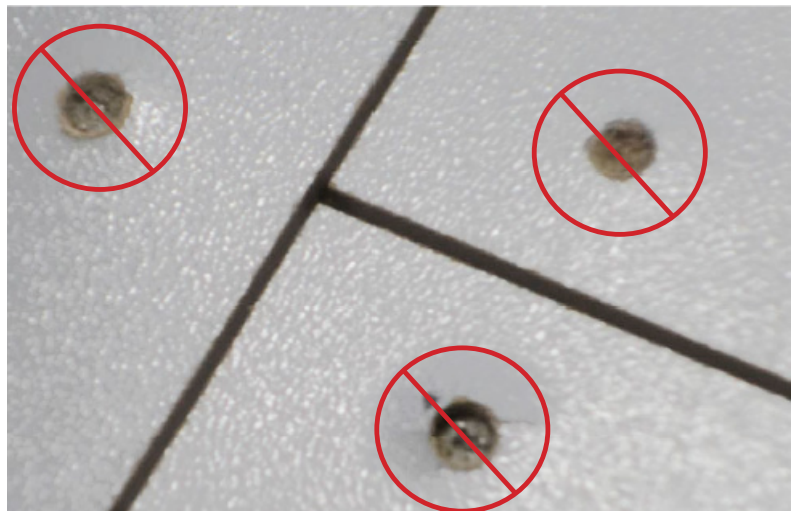
*Figure E.*



When fasteners / fixings are installed too deeply, mounding of the ResinDek® panels can sometimes occur. This is cosmetic, not a structural problem, and will not impact the 10-year warranty. This problem can be prevented by using the counter bore bits prior to screw installation as shown in this photo. In addition to preventing mounding, and controlling screw depths better, the counter bores serve to locate the center of rib locations after the panel has been laid in place.



*Image above shows a fastener / fixing that has been installed correctly.*



*Image above shows fasteners / fixings that have been installed too deeply.*



## 8. Grounding Screw Fasteners / Fixings Installation

### ResinDek® ESD Grounding Screws

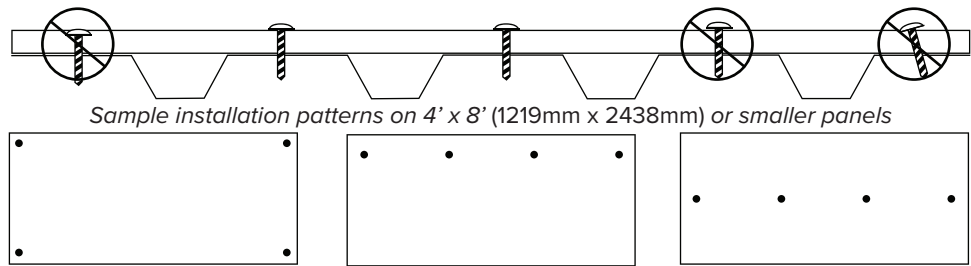
For proper grounding performance of ResinDek® Gray Diamond Seal® ESD, TriGard® ESD, TriGard® ESD Ultra or MetaGard® panels install four (4) grounding screws on any panel that is 4'x8' (1219mm x 2438mm) or less. Larger panels will require additional grounding screws. Examples of grounding screw installation patterns can be seen below (Figure F). Distance to the closest screw must not exceed 4' (1219mm), regardless of panel size.

**PROPERLY INSTALLED GROUNDING SCREWS ARE NECESSARY FOR A FULLY COMPLIANT ESD FLOOR.**

The underside of the grounding screw head must be installed flush with the top surface of the panel. Be careful to not strip out screws from the corrugated decking. ResinDek® panels attached to the corrugated metal deck requires a minimum of 0.625 screws per 1 sqft (0.093 m<sup>2</sup>) which equals 20 screws per 4'x8' (1219mm x 2438mm) sheet. For panels that have ResinDek® Gray Diamond Seal® ESD, TriGard® ESD, or TriGard® ESD Ultra coating, the grounding screws will count towards the minimum requirement of fasteners / fixings.

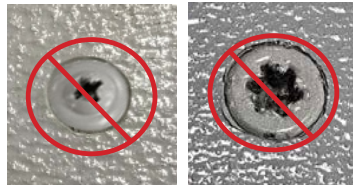


**Figure F - ESD Screw Installation**  
Cross Section - Screws must be flush with deck surface!

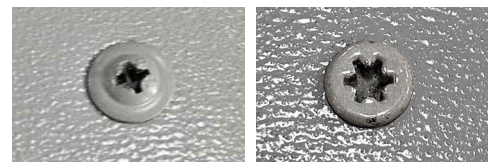


Also, for best results, care should be taken to install the fasteners / fixings at least .984" (25mm) from the edge of the panels.

If ESD panels are selected, Grounding Screws are to be used to dissipate static charges generated by the contact and separation between the flooring surface and shoes or wheels. These screws are designed to be installed such that the screw heads rest on top of the surface, rather than below the surface per above sketch.

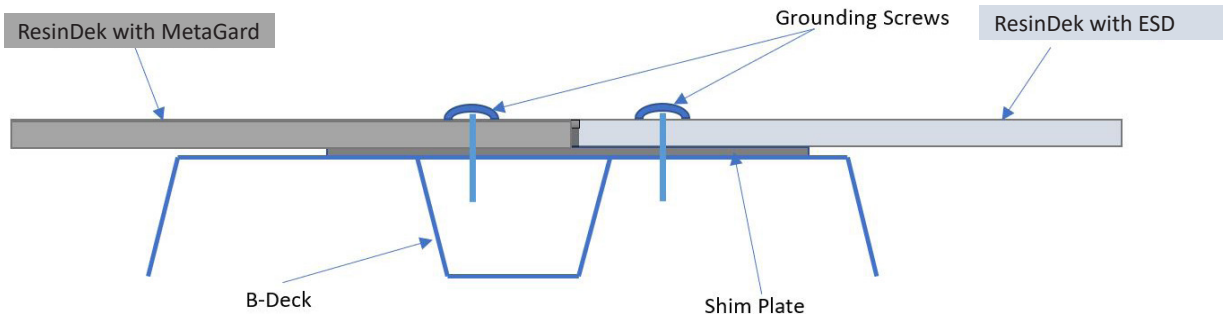


The left photos show examples where the grounding screws were installed too deeply. In this instance, the depth of the grounding screw may adversely impact its ability to transmit the charge away from the panel surface into ground. It is recommended that an additional grounding screw be installed adjacent to the improperly installed screw.



The photos to the right show examples where the grounding screws were installed correctly.

### Grounding Screw Scenario





# CORNERSTONE

SPECIALTY WOOD PRODUCTS, LLC®

12020 Tramway Drive

Cincinnati, OH 45241

Toll Free: 888.755.3048 | Tel: 513.772.5560

Email: [info@resindek.com](mailto:info@resindek.com) | [www.resindek.com](http://www.resindek.com)



Storage Manufacturers Association

